



TECHNICAL GUIDE

SINGLE PACKAGE

HEAT PUMP / ELECTRIC HEAT

16 SEER – R-410A – 208/230V - 3 PHASE

3 THRU 5 NOMINAL TONS

MODELS: PHE6*36 THRU 60



Due to continuous product improvement, specifications are subject to change without notice.

Visit us on the web at www.upgnet.com and www.york.com

Additional rating information can be found at: www.ahridirectory.org

WARRANTY SUMMARY*

Standard 1-Year limited parts warranty.

Standard 5-Years limited compressor warranty.

*See limited warranty certificate in User's Information Manual for details.

DESCRIPTION

These packaged cooling/heating heat pumps are designed for outdoor installation. Only utility and duct connections are required at the point of installation.

FEATURES

- **Operating Efficiency** - The PHE6 heat pump models are rated at 16.0 SEER, 12.5 EER and 8.2 HSPF per DOE procedures and are AHRI certified. All PHE6 models utilize multi-stage compressors for maximum comfort and efficiency.
- **On Site Flexibility** - All model sizes use a compact design cabinet in one footprint. Field convertible duct connections from side shot to down shot allows the installer to have greater flexibility with less inventory.
- **Lower Installation Cost** - Installation time and costs are reduced by easy power and control wiring connections. All units are completely wired, charged with R-410A refrigerant and tested prior to shipment. Test stations using a state-of-the-art computerized process system are used to insure product quality. Refrigerant charge and component part numbers are verified via computers during assembly. Vital run test statistics such as system pressure, motor currents, air velocity and temperature, unit vibration, and gas system safeties are monitored and recorded by the system to insure unit performance. Equal size side supply and return duct connections allow easy connection of ducts to match low crawl spaces without transition pieces.
- **Utility Connections Made Easy** - Electric utility access provided through the bottom or the side of the unit. Utility connections can be made quickly and with a minimum amount of field labor. A field supplied and field installed electrical disconnect switch must be installed.
- **Convertible Airflow Design** - The bottom duct openings are covered when they leave the factory, ready to be used for a side supply/side return application. If a bottom supply/bottom return application is desired, simply remove the two panels from the bottom of the unit and place them in the side supply/side return duct openings. No panel cutting is required and no accessory panel is necessary. Convertible airflow design allows maximum field flexibility and minimum inventory.
- **Condensate Pan** - A corrosion-resistant, long-lasting, water-tight pan is positioned below the indoor coil to collect and drain all condensate, preventing build-up of stagnant condensate. The condensate pan conforms to ASHRAE 62-89 standards (Ventilation for Acceptable Indoor Air Quality).
- **Condensate Drain** - The 3/4 inch NPT female connection is rigidly mounted to assure proper fit and leak tight seal.
- **Durable Finish** - The cabinet is made of G90 galvanized steel with a powder paint coating for appearance and protection. The pre-treated galvanized steel provides a better paint-to-steel bond, which resists corrosion and rust creep. Powder paint finish insure less fading when exposed to sunlight, and provides superior corrosion resistance (1000 hour salt spray tested).

Continued on next page.

- **Full Perimeter Base Rails** - The easily removable base rails provide a solid foundation for the entire unit and protects the unit during shipment. The rails provide fork lift access from all sides, and rigging holes are also provided so that an overhead crane can be used to place the units on a roof. On applications where the unit is placed on a pad, the base will keep the unit off the pad to deter corrosion. On applications where height is limited, the base rails may be removed by removing 2 screws in each corner.
- **Attractive Appearance** - A single-piece top cover containing a top-discharge outdoor fan arrangement requires less square footage on installation and provides a wider variety of installations. The one-piece design adds greater water integrity. Rounded corners with water drip edges add to the attractive appearance and provide cut protection to the installer
- **Top Discharge** - The top-discharge outdoor fan does not disrupt neighboring areas or dry out vegetation surrounding the unit. The warm air from the top mounted fan is blown up and away from the structure and any landscaping.
- **Outdoor Coil Grille** - All models utilize a stamped slotted design which provides superior impact protection against small objects during transit and after installation.
- **Low Operating Sound Level** - The upward air flow carries the normal operating noise up and away from the living area. The rigid top panel effectively isolates noise. Isolator mounted compressor and the rippled fins of the outdoor coil muffle the normal fan motor and compressor operating sounds. The unique formed base pan also aids in sound attenuation with its structural design.
- **Low Maintenance** - Long life, permanently lubricated outdoor and indoor fan motor bearings need no annual maintenance, adding greater reliability to the unit. Slide-out blower assembly can be easily removed for cleaning or service.
- **Fan System** - All models operate over a wide range of design conditions with an enhanced ECM indoor fan motor. These units easily match all types of applications and provide greater on-site flexibility to match comfort requirements. The cooling speed and heating speeds are factory set at test design conditions but can be field adjusted. This allows maximum comfort capabilities.
- **Dehumidification/Humidity Switch Input** - This model unit features a built in de-humidification feature for advanced dehumidification during cooling operation. The unit indoor blower control is designed to work with a humidity control that closes when the humidity is below the set-point. The control is open when the humidity is above the set-point. This humidity control may be referred to as a humidistat or dehumidistat.

To use this feature, the control HUM STAT jumper must be set to YES and a humidistat is connected from the low voltage R and HUM color coded leads. During cooling operation if the humidity level is above the humidistat set point, the indoor blower speed is reduced by approximately 15%.
- **Simple Control Circuit** - An indoor enhanced ECM blower control board and a defrost control board each contain a status/diagnostic indicator light. Field thermostat wiring connects to color coded leads using twist on wire connections. Cooling controls use a contactor and a 2nd stage 24 VAC to 24 VDC rectifier for simple application and troubleshooting. Mate-n-lock plug connectors are used. The electrical control box is not located in the compressor compartment. The controls are mounted to allow the separate access panel to be removed for trouble shooting and maintenance without affecting the normal system operating pressures. All wiring internal to the unit is color/number coded.
- **Protected Compressor** - The compressor is internally protected against high pressure and temperature. This is accomplished by the simultaneous operation of scroll bypass and a temperature thermal overload sensor which protect the compressor if undesirable operating conditions occur.
- **Pressure Switch** - A high pressure switch is standard in all units. When abnormal conditions are sensed through the pressure switch, the unit will lock out preventing any further operation until unit is reset.
- **Loss of Charge Switch** - All models include a loss of charge switch to provide safe shutdown of compressor.
- **Exclusive Coil Design** - Grooved copper tubes and enhanced aluminum fin construction improves heat transfer for maximum efficiency and durability for long-lasting durability and efficient operation. Indoor coils will use tin-coated copper tubing with aluminum fins for effective heat transfer.
- **Electric Heat (Optional)** - All PHE models use 6HK electric heat kits, which are available in 230V/3/60 from 10 kW to 25 kW. Single point field wiring kits are available for all applications.
- **Easy Service Access** - Individual access panels are provided in access to all major components - compressors, indoor coils, blower, controls/electric heat kits, filters, etc. that makes servicing easy. Removing these panels allow easy removal of the components such as the blower assembly for maintenance and ease of troubleshooting.
- **Replacement Parts** - The installer requires no special training to replace any of the components of these units and the number of new components have been reduced to minimize the inventory of unique parts.
- **Controls** - Demand defrost curves pre-loaded into defrost control for optimized performance based on unit capacities.
- **Filter Frame Kit** - All 3 phase PHE units include a filter frame kit, which is shipped inside the unit from production. Field installation is required.
- **Filters** - All 3 phase PHE units include an applicable number of 1" washable filters, which are shipped inside the unit from production. Field installation is required. Two filters are required for A base units. Three filters are required for B base units.

NOMENCLATURE

PHE	4	A	24	2	1	A
1	2	3	4	6	8	9
1. Model Family PHE - packaged heat pump with electric heat PCG - packaged A/C with gas heat, PHG - packaged heat pump with gas heat, PCE - packaged A/C with electric heat,				5. Gas Heating Input BTU/Hr x 1000 050 = 50,000 BTU/Hr. input, blank = electric heat		
2. Nominal Cooling Efficiency 4 = 14 SEER, 6 = 16 SEER, etc.				6. Voltage-Phase-Frequency 2 = 208/230-1-60, 3=208/230-3-60, 4 = 460-3-60		
3. Cabinet Size A = small 35 x 51, B = large 45 x 51				7. NOx Approval X = low-NOx, blank = not low-Nox		
4. Nominal Air Conditioning Cooling Capacity BTUx1000 24 = 24,000 BTU, etc.				8. Generation Level 1 = first generation		
				9. Revision Level A = original release, B = second release		
Examples: PHE6B4221A is a packaged heat pump, 16 SEER, 3-1/2 ton, large cabinet, 230 volt, single phase model, (first generation, first release).						

COMPONENT LOCATION

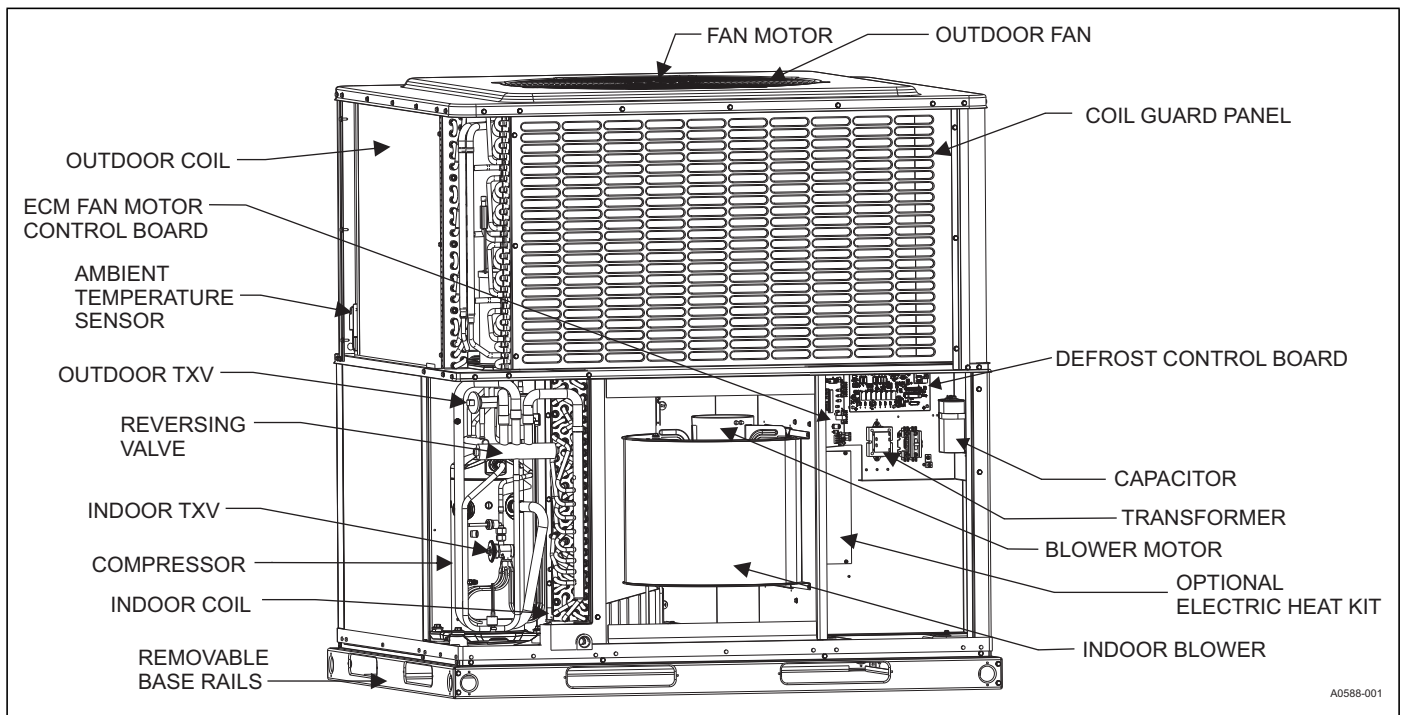

UNIT LIMITATIONS

Model	Unit Voltage	Unit Limitations		
		Applied Voltage		Outdoor DB Temp
		Min	Max	Max (°F)
PHE6B3631	208/230-3-60	187	252	125
PHE6B4831	208/230-3-60	187	252	125
PHE6B6031	208/230-3-60	187	252	125

ACCESSORIES

- **Economizer for Downflow Applications (S1-2EE04710024, S1-2EE04710124)** - Modulating integrated economizer provides simultaneous operation between mechanical cooling and economizer operation. Independent blade design insures proper control and less than 1% leak rate. Includes hood and mesh bird screen filter integrated into the hood, dry bulb sensor and relief damper. Separate field accessories of single/dual enthalpy kits are also available.
- **Economizer for Horizontal Applications (S1-2EE04710224, S1-2EE04710324)** - Modulating integrated economizer provides simultaneous operation between the mechanical cooling and economizer operation. Independent blade design insures proper control and less than 1% leak rate. Includes hood and mesh bird screen filter integrated into hood, dry bulb sensor and relief damper. Separate field accessories of single enthalpy and dual enthalpy are available.
- **Single/Dual Enthalpy Sensor (S1-HE-6863-0N00WS)** - Sensor replaces dry bulb sensor standard in economizer kit. Provides improved economizer operation by sensing the dry bulb temperature from outdoors plus the enthalpy content of the outdoor air.
- **Duct/Unit Mount CO2 Kit (S1-2AQ04700924)** - Sensor kit detects CO2 levels automatically and overrides the economizer when CO2 levels rise above the preset limits.
- **Wall Mount CO2 Kit (S1-2AQ04701024)** - Sensor kit detects CO2 levels automatically and overrides the economizer when CO2 levels rise above the preset limits.
- **Supply Air Temperature Sensor Kit (S1-TE-63616E-2D)** - Outdoor supply air temperature sensor kit used with economizers.
- **Filter/Frame Kit (Kit provided) (S1-1FF0602, S1-1FF0601)** - Kit contains the necessary hardware to field install return air filters into the base unit. The filter rack is suitable for either 1" or 2" filters.
- **Filter (S1-02647812000)** - Washable 1" filter. Two filters are required for A base units. Three filters are required for B base units.
- **Motorized Fresh Air Damper (S1-2MD04705224, S1-2MD04705124)** - Designed for duct mounted side supply/return and unit mounted down supply/return applications. Damper capable of providing 0% through 50% of outdoor air (field supplied). Closes on power loss, includes hood and screen assembly.
- **Rectangle to Round (Horizontal) Adapter (S1-1AK0110, S1-1AK0111)** - Kit includes one supply and one return air rectangle to round duct adapter. Adapters are preformed and designed to fit over current horizontal duct openings on the base unit. Transition is from rectangle to 12" round for the 1AK0110 kit and from rectangle to 14" round for the 1AK0111 kit.
- **Rectangle to Round (Downflow) Adapter (S1-1AK0108, S1-1AK0109)** - Kit includes one supply and one return air rectangle to round duct adapter. Adapters are preformed and designed to fit into current downflow duct openings on the roof curb. Transition is from rectangle to 16" round for the 1AK0108 kit and from rectangle to 18" round for the 1AK0109 kit.
- **Roof Curbs (S1-1RC0503, S1-1RC0501)** - NRCA approved curbs provide proper fit to base unit for rooftop installations. Curbs are designed to be assembled through hinge pins in each corner. Kit also provides seal strip to assure an air tight seal. These are 8 inch high roof curbs.
- **Roof Curbs (S1-1RC0504, S1-1RC0502)** - NRCA approved curbs provide proper fit to base unit for rooftop installations. Curbs are designed for assembly through hinge pins in each corner. Kit also provides seal strip to assure air tight seal. These are 14 inch high roof curbs.
- **Transition Curb Kits (S1-1TC01*)** - Adapter kits to allow field use of pre-existing installed roof curbs to match PHE6 footprint to Affinity roof curbs, Carrier, Trane, or Goodman curb footprints. Curb adapters are optional for current generation Carrier replacements but are recommended for previous generation applications. Refer to the PHE6 price pages for more details.
- **Manual Outdoor Damper (S1-1FA0502, S1-1FA0501)** - Provides 0% through 50% outdoor air capability (field adjustable). Designed for duct mounted side supply/return applications and unit mounted down supply/return applications. Includes hood and screen assembly.
- **Loss of Charge Switch (S1-2LC00024)** - Kit provides Loss of Charge switch and wiring to provide safe shutdown of compressor.
- **Low Ambient Kit (S1-2LA04701024)** - Kit provides necessary hardware to convert unit to operate in cooling cycle down to 0° F. Standard unit operation 45° F.
- **Base Rail Hole Cover Kit (S1-1HC0101)** - Kit provides necessary hardware to close off openings in base rails to block off openings, i.e. prevent animal entrance.
- **Single Point Wiring Kits for 6HK Electric Heat Applications (S1-SPWK*)** - Kit provides field option for connecting electrical power supplies to the field installed 6HK heat kits and the package unit power supply to a single source of power.
- **Thermostat (S1-THXU280*)** - Compatible thermostat controls are available through accessory sourcing. For optimum performance, these outdoor units are fully compatible with the York Hx™ Touchscreen Thermostat (S1-THXU280*) available through Source1. For more information, see the thermostat section of the Product Equipment Catalog.
- **Wall Thermostat** - The units are designed to operate with standard, 24-volt electronic non power stealing and electro-mechanical thermostats. All units require the use of a 3 heat / 2 cool (3H/2C) heat pump thermostat - with or without the economizer.

* For additional kit numbers refer to the price pages.

GUIDE SPECIFICATIONS

GENERAL

Units shall be manufactured by Unitary Products in an ISO 9001 certified facility. These packaged cooling/heating air conditioners are designed for outdoor installation. Only utility and duct connections are required at the point of installation. Heat pumps provide electric cooling and electric heating, with field installed electric heat kits from 10 kW to 25 kW for backup supplemental heating operation.

DESCRIPTION

Units shall be factory-assembled, single packaged, Heat Pumps with Electric Cooling/Electric Heating units, designed for outdoor installation. They shall have built in, equal size, field convertible duct connections for downflow supply/return or horizontal supply/return. The units shall be factory wired, piped, and charged with R-410A Refrigerant and factory tested prior to shipment. All models shall be rated in accordance with DOE and AHRI test procedures for both heating and cooling operation. Units shall be CSA listed to the UL 1995/CAN/CSA No. 236-M90 standards.

- **Operating Efficiency** - All heat pump models shall be rated at a minimum of 16.0 SEER, 12.5 EER and 8.2 HSPF for cooling and heating operation.
- **Low Operating Sound Level** - The upward air flow carries the normal operating noise up and away from the living area. The rigid top panel effectively isolates noise. Isolator mounted compressor and the rippled fins of the outdoor coil muffle the normal fan motor and compressor operating sounds. The unique formed base pan also aids in sound attenuation with its structural design. Sound ratings as tested under AHRI test procedures shall be less than 77 dbA for all models.

UNIT CABINET

Unit cabinet shall be a single piece design, with drip edges and no-seam corners to provide optimum water integrity. Unit shall have a rigidly mounted outdoor coil guard to provide protection from objects and personnel after installation. Indoor blower section shall be insulated with foil-faced or foam insulation, fastened to prevent insulation from entering the air stream. Cabinet panels shall be separate, easily removable for servicing and maintenance. Unit shall be built on a formed, design base pan, with embossments at critical points to add strength and rigidity and to aid in minimizing sound. Full perimeter base rails shall be provided to assure reliable transit of equipment, overhead rigging, for fork truck access and proper sealing on roof curb applications. Base rails shall be easily removable, when required to lower unit height. Filters shall be field installed, furnished and be accessible through a removable access door, sealed airtight. Units vertical discharge and return duct configuration shall be designed to fit between standard 24" O.C. beams without modification to building structure, duct work and base unit.

- **On Site Flexibility** - All model sizes shall use a compact design cabinet in one of two footprints. This provides installer flexibility for placing the proper capacity unit on curbs or pads with the smallest footprint after the internal load has been determined. Field convertible duct connections from side shot to down shot allows the installer to have greater flexibility with less inventory.

- **Durable Finish** - The cabinet shall be made of G90 galvanized steel with a powder paint coating for appearance and protection. The pre-treated galvanized steel shall provide a better paint-to-steel bond, which resists corrosion and rust creep. Powder paint finish insure less fading when exposed to sunlight, and provides superior corrosion resistance (1000 hour salt spray tested).
- **Attractive Appearance** - A single-piece top cover containing a top-discharge outdoor fan arrangement shall be used which requires less square footage on installation and provides a wider variety of installations. The one-piece design adds greater water integrity. Rounded corners with water drip edges add to the attractive appearance and prevent water penetration.
- **Convertible Airflow Design** - The bottom duct openings are covered when they leave the factory, ready to be used for a side supply/side return application. If a bottom supply/bottom return application is desired, simply remove the two panels from the bottom of the unit and place them in the side supply/side return duct openings. No panel cutting is required and no accessory panel is necessary. Convertible airflow design allows maximum field flexibility and minimum inventory.
- **Utility Connections Made Easy** - Electric utility access shall be provided through the bottom or the side of the unit. Utility connections should be made quickly and with a minimum amount of field labor. A field supplied and field installed electrical disconnect switch must be installed.
- **Easy Service Access** - Individual access panels are provided in access to all major components - compressors, indoor coils, blower, controls/electric heat kits, filters, etc. that makes servicing easy. Removing these panels allow easy removal of the components such as the blower assembly for maintenance and ease of troubleshooting.
- **Top Discharge** - The top-discharge outdoor fan does not disrupt neighboring areas or dry out vegetation surrounding the unit. The warm air from the top mounted fan is blown up and away from the structure and any landscaping.
- **Outdoor Coil Grille** - All models utilize a stamped slotted design which provides superior impact protection against small objects during transit and after installation.

Indoor Blower Assembly - Blower shall be direct drive design. Blower wheel shall be double-inlet type with forward-curved blades, dynamically balanced to operate smoothly throughout the entire range of operation. Design shall use constant torque motors. Bearings shall be sealed and permanently lubricated for longer life and no maintenance. Fan assembly shall be a slide-out design for easy removal and cleaning. Indoor blower motors shall be equipped with a standard high efficiency brushless DC motor (constant torque) also known as an enhanced ECM motor.

Outdoor Fan Assembly - The outdoor fan shall be of the direct-driven propeller type, discharge air vertically, have aluminum blades riveted to corrosion resistant steel spider bracket and shall be statically balanced for smooth operation. The outdoor fan motor shall be totally enclosed with permanently lubricated ball bearings and internally protected against overload conditions.

REFRIGERANT COMPONENTS

- **Protected Compressor** - The compressor shall be a fully hermetic type, direct drive compressor, that is internally protected against high pressure and temperature. This is accomplished by the simultaneous operation of operation of scroll bypass and a temperature thermal overload sensor which protect the compressor if undesirable operating conditions occur. The hermetic motor shall be suction gas cooled and have a voltage range of +/- 10% of the unit nameplate voltage. Compressors shall have internal isolation and sound muffling to minimize vibration and noise, and be externally isolated on a dedicated, independent mounting.
- **Indoor Coils** - Indoor coils shall be of the direct expansion, draw through design and have aluminum plate fins mechanically bonded to seamless internally enhanced tin-coated copper tubes with all joints brazed.
- **Condensate Pan** - A corrosion-resistant, long-lasting, water-tight pan is positioned below the indoor coil to collect and drain all condensate, preventing build-up of stagnant condensate. The condensate pan conforms to ASHRAE 62-89 standards (Ventilation for Acceptable Indoor Air Quality).
- **Condensate Drain** - The 3/4 inch NPT female connection is rigidly mounted to assure proper fit and leak tight seal.
- **Outdoor Coils** - Outdoor coils shall have aluminum plate fins mechanically bonded to seamless internally enhanced copper tubes with all joints brazed, and be a draw through design.
- **Refrigerant Circuit and Refrigerant Safety Components shall include:** Thermal expansion devices (TXV's) shall be factory mounted and provided, Filter/strainer to eliminate any foreign matter, reversing valves to control refrigerant flow.

CONTROLS

- **Simple Control Circuit** - An indoor enhanced ECM blower control board and a defrost control board each contain a status/diagnostic indicator light. Field thermostat wiring connects to color coded leads using twist on wire connections. Cooling controls use a contactor and a 2nd stage 24 VAC to 24 VDC rectifier for simple application and troubleshooting. Mate-n-lock plug connectors are used. The electrical control box is not located in the compressor compartment. The controls are mounted to allow the separate access panel to be removed for trouble shooting and maintenance without affecting the normal system operating pressures. All wiring internal to the unit is color/number coded.
- **Controls** - Demand defrost curves pre-loaded into defrost control for optimized performance based on unit capacities.
- **Pressure Switch** - A high pressure switch is standard in all units. When abnormal conditions are sensed through the pressure switch, the unit will lock out preventing any further operation until unit is reset.
- **Loss of Charge Switch** - A loss of charge switch is standard in all units. When excessive compressor discharge temperatures are sensed, the unit locks out preventing any further operation until unit is reset.
- **Factory Testing** - Installation time and costs are reduced by easy power and control wiring connections. All units are completely wired, charged with refrigerant R-410A refrigerant and tested prior to shipment. Test stations using a state-of-the-art computerized process system shall be used to insure product quality. Refrigerant charge and component part numbers are verified via computer bar code scans during assembly. Vital run test statistics such as system pressure, motor currents, air velocity and temperature, unit vibration, and gas system safeties are monitored and recorded by the system to insure unit performance. This data could be provided by serial number tracking if necessary.
- **Electric Heat (Optional)** - All PHE models use 6HK electric heat kits, which are available in 230V/3/60 from 10 kW to 25kW. Single point field wiring kits are available for all applications. Electric heat kits must be certified to UL 1995 standard requirements.

PHYSICAL DATA

NOMINAL TONNAGE	MODELS		
	PHE6B36	PHE6B48	PHE6B60
	3.0	4.0	5.0
AHRI Cooling Performance			
Gross Capacity @ AHRI A point (MBH)	37.0	49.1	59.2
AHRI net capacity (MBH)	36.4	47.5	57.5
EER	12.5	12.5	12.5
SEER	16.0	16.0	16.0
Nominal CFM	1200	1600	1800
System power (kW)	2.8	3.7	4.5
Refrigerant type	R410A	R410A	R410A
Refrigerant charge (lb-oz)	12-12	15-0	15-8
AHRI Heating Performance			
47 Capacity Rating (MBH)	33.3	47.4	57.2
System Power (kW/COP)	3.6	3.6	3.6
17 F Capacity Rating (MBH)	19.0	28.0	32.5
HSPF (BTU/Watts-hr.)	8.2	8.2	8.2
Dimensions (inches)			
Length	51-1/4	51-1/4	51-1/4
Width	45-3/4	45-3/4	45-3/4
Height	49	53	55
Operating WT. (lbs.)	448	496	523
Compressors			
Type	Scroll	Scroll	Scroll
Stages	2	2	2
Outdoor Coil Data			
Face area (Sq. Ft.)	19.5	23.8	25.9
Rows	2	2	2
Fins per inch	22	22	22
Tube diameter	3/8	3/8	3/8
Circuitry Type	Interlaced	Interlaced	Interlaced
Refrigerant control	TXV	TXV	TXV
Indoor Coil Data			
Face area (Sq. Ft.)	6.3	6.3	6.3
Rows	3	3	4
Fins per inch	16	16	16
Tube diameter	3/8	3/8	3/8
Circuitry Type	Interlaced	Interlaced	Interlaced
Refrigerant control	TXV	TXV	TXV
Outdoor Fan Data			
Fan diameter (Inch)	26	26	26
Type	Prop	Prop	Prop
Drive type	Direct	Direct	Direct
No. speeds	1	1	1
Motor HP each	1/3	1/3	1/3
RPM	850	850	850
Nominal total CFM	4000	4200	4200
Direct Drive Indoor Blower Data			
Fan Size (Inch)	11 x 10	11 x 10	11 x 10
Type	Centrifugal	Centrifugal	Centrifugal
Motor HP each	1/2	3/4	1
RPM	1200 Max	1200 Max	1200 Max
Frame size	48	48	48
Filters			
Filter size	B	B	B
Quantity - Size	Field-supplied external filters must be sized so as not to exceed 300 fpm air velocity through disposable filters. For internal filter use, a filter rack kit is available. Consult the instructions supplied with that kit for replacement filter sizes. Filter sizes: A=20x20, B=20x30.		

HEATING PERFORMANCE DATA - 3.0 TON (LOW SPEED)										
PACKAGED UNIT MODEL NO. PHE6B36										
AIR TEMPERATURE ENTERING OUTDOOR UNIT	AIR TEMPERATURE ENTERING INDOOR COIL	ID CFM								
		600			800			1000		
		MBH	COP	KW	MBH	COP	KW	MBH	COP	KW
60	60	30.3	5.01	1.72	29.4	4.36	1.89	28.4	3.84	2.07
	70	29.0	4.28	1.93	28.0	3.74	2.12	27.0	3.29	2.31
	80	27.8	3.69	2.15	26.6	3.22	2.34	25.5	2.83	2.54
47	60	25.3	4.18	1.72	24.3	3.67	1.87	23.3	3.24	2.01
	70	23.8	3.51	1.93	22.9	3.11	2.08	22.0	2.77	2.24
	80	22.2	2.96	2.14	21.5	2.65	2.30	20.8	2.38	2.47
40	60	22.0	3.63	1.72	21.2	3.22	1.85	20.4	2.88	1.99
	70	20.6	3.06	1.92	19.9	2.72	2.07	19.1	2.43	2.21
	80	19.3	2.59	2.13	18.6	2.31	2.28	17.9	2.07	2.44

HEATING PERFORMANCE DATA - 3.0 TON (HIGH SPEED)										
PACKAGED UNIT MODEL NO. PHE6B36										
AIR TEMPERATURE ENTERING OUTDOOR UNIT	AIR TEMPERATURE ENTERING INDOOR COIL	ID CFM								
		1000			1200			1400		
		MBH	COP	KW	MBH	COP	KW	MBH	COP	KW
60	60	43.9	4.52	2.53	43.0	4.45	2.58	42.0	4.37	2.64
	70	42.1	4.01	2.76	41.2	3.94	2.82	40.3	3.87	2.88
	80	40.2	3.57	2.99	39.5	3.51	3.05	38.7	3.44	3.11
47	60	36.0	3.84	2.44	35.7	3.85	2.47	35.3	3.85	2.50
	70	34.5	3.41	2.66	34.1	3.39	2.70	33.7	3.37	2.75
	80	33.1	3.04	2.88	32.5	3.00	2.93	32.0	2.96	2.99
40	60	31.9	3.45	2.40	31.4	3.45	2.42	30.9	3.45	2.45
	70	30.5	3.04	2.62	30.0	3.04	2.65	29.6	3.03	2.69
	80	29.0	2.69	2.84	28.6	2.68	2.89	28.3	2.67	2.93
30	60	26.6	2.93	2.34	26.1	2.97	2.33	25.6	3.01	2.31
	70	25.4	2.59	2.56	25.0	2.60	2.57	24.6	2.62	2.57
	80	24.2	2.29	2.78	23.9	2.29	2.81	23.6	2.29	2.83
17	60	20.0	2.26	2.27	19.7	2.30	2.26	19.4	2.33	2.25
	70	18.8	1.97	2.48	18.6	2.00	2.48	18.5	2.03	2.49
	80	17.6	1.72	2.69	17.5	1.74	2.70	17.5	1.77	2.72
10	60	15.9	1.83	2.24	16.3	1.93	2.22	16.6	2.05	2.20
	70	8.5	0.95	2.30	12.0	1.35	2.36	15.6	1.75	2.42
	80	1.1	0.12	2.38	7.8	0.83	2.50	14.5	1.51	2.64

HEATING PERFORMANCE DATA - 4.0 TON (LOW SPEED)										
PACKAGED UNIT MODEL NO. PHE6B48										
AIR TEMPERATURE ENTERING OUTDOOR UNIT	AIR TEMPERATURE ENTERING INDOOR COIL	ID CFM								
		1000			1200			1400		
		MBH	COP	KW	MBH	COP	KW	MBH	COP	KW
60	60	44.4	4.83	2.48	44.3	4.55	2.68	44.1	4.31	2.89
	70	42.2	4.08	2.80	41.9	3.82	3.05	41.7	3.59	3.29
	80	39.9	3.48	3.14	39.6	3.24	3.42	39.3	3.02	3.70
47	60	35.9	3.90	2.48	35.9	3.71	2.67	35.9	3.54	2.85
	70	33.6	3.25	2.81	33.4	3.08	3.01	33.3	2.92	3.21
	80	31.3	2.72	3.15	31.0	2.57	3.36	30.6	2.43	3.57
40	60	31.4	3.41	2.48	31.3	3.25	2.65	31.2	3.11	2.82
	70	29.3	2.87	2.78	29.3	2.73	2.98	29.3	2.61	3.17
	80	27.3	2.42	3.08	27.3	2.30	3.30	27.3	2.20	3.51

HEATING PERFORMANCE DATA - 4.0 TON (HIGH SPEED)										
PACKAGED UNIT MODEL NO. PHE6B48										
AIR TEMPERATURE ENTERING OUTDOOR UNIT	AIR TEMPERATURE ENTERING INDOOR COIL	ID CFM								
		1300			1500			1700		
		MBH	COP	KW	MBH	COP	KW	MBH	COP	KW
60	60	61.4	4.63	3.46	60.8	4.52	3.56	60.1	4.42	3.68
	70	58.7	4.04	3.82	58.2	3.93	3.97	57.7	3.82	4.12
	80	56.0	3.55	4.19	55.7	3.43	4.38	55.3	3.32	4.57
47	60	50.9	3.97	3.32	50.3	3.87	3.43	49.6	3.78	3.53
	70	48.3	3.43	3.71	48.0	3.34	3.83	47.7	3.26	3.97
	80	45.8	2.97	4.09	45.8	2.91	4.24	45.7	2.84	4.40
40	60	44.7	3.51	3.30	44.7	3.48	3.39	44.6	3.45	3.48
	70	42.6	3.02	3.70	42.6	2.99	3.81	42.7	2.95	3.92
	80	40.5	2.62	4.09	40.6	2.58	4.23	40.7	2.55	4.36
30	60	36.8	2.92	3.25	36.9	2.93	3.31	37.0	2.94	3.38
	70	35.1	2.55	3.59	35.2	2.51	3.73	35.3	2.47	3.88
	80	33.4	2.24	3.94	33.5	2.17	4.15	33.6	2.10	4.38
17	60	28.0	2.26	3.20	28.2	2.29	3.23	28.4	2.33	3.26
	70	26.3	1.94	3.55	26.6	1.94	3.64	26.9	1.95	3.73
	80	24.6	1.66	3.90	25.0	1.66	4.05	25.4	1.65	4.19
10	60	25.3	2.11	3.08	25.5	2.14	3.11	25.6	2.17	3.15
	70	23.3	1.76	3.44	23.5	1.78	3.49	23.9	1.81	3.55
	80	21.2	1.47	3.78	21.6	1.49	3.86	22.1	1.52	3.95

HEATING PERFORMANCE DATA - 5.0 TON (LOW SPEED)										
PACKAGED UNIT MODEL NO. PHE6B60										
AIR TEMPERATURE ENTERING OUTDOOR UNIT	AIR TEMPERATURE ENTERING INDOOR COIL	ID CFM								
		1030			1230			1430		
		MBH	COP	KW	MBH	COP	KW	MBH	COP	KW
60	60	53.8	4.73	2.98	54.5	4.57	3.22	55.1	4.42	3.47
	70	51.7	4.09	3.34	52.2	3.93	3.61	52.7	3.79	3.88
	80	49.6	3.57	3.72	49.9	3.42	4.01	50.2	3.28	4.30
47	60	45.2	4.06	2.91	46.3	4.03	3.09	47.3	4.01	3.27
	70	43.2	3.50	3.25	44.0	3.46	3.46	44.9	3.42	3.67
	80	41.1	3.04	3.60	41.8	2.98	3.83	42.5	2.94	4.05
40	60	40.6	3.66	2.90	41.1	3.62	3.05	41.6	3.60	3.21
	70	38.4	3.14	3.23	39.0	3.12	3.40	39.7	3.09	3.57
	80	36.3	2.72	3.55	37.0	2.70	3.75	37.7	2.68	3.94

HEATING PERFORMANCE DATA - 5.0 TON (HIGH SPEED)										
PACKAGED UNIT MODEL NO. PHE6B60										
AIR TEMPERATURE ENTERING OUTDOOR UNIT	AIR TEMPERATURE ENTERING INDOOR COIL	ID CFM								
		1530			1730			1930		
		MBH	COP	KW	MBH	COP	KW	MBH	COP	KW
60	60	73.6	4.77	4.15	73.1	4.56	4.18	72.5	4.37	4.21
	70	70.6	4.22	4.53	70.2	4.03	4.60	69.8	3.85	4.67
	80	67.6	3.74	4.92	67.4	3.57	5.01	67.2	3.42	5.11
47	60	61.4	4.17	3.94	61.5	4.02	3.97	61.6	3.88	4.01
	70	58.8	3.66	4.33	59.0	3.53	4.38	59.1	3.42	4.43
	80	56.2	3.23	4.73	56.4	3.12	4.78	56.6	3.02	4.84
40	60	54.6	3.76	3.88	54.8	3.66	3.88	55.1	3.57	3.88
	70	52.2	3.30	4.26	52.2	3.19	4.28	52.3	3.10	4.30
	80	49.7	2.90	4.65	49.6	2.80	4.69	49.5	2.70	4.73
30	60	44.5	3.17	3.74	44.9	3.11	3.72	45.3	3.06	3.70
	70	42.8	2.80	4.11	43.3	2.75	4.10	43.8	2.70	4.10
	80	41.1	2.48	4.48	41.7	2.44	4.49	42.3	2.40	4.51
17	60	33.4	2.46	3.60	33.3	2.41	3.54	33.2	2.36	3.48
	70	31.5	2.14	3.94	31.9	2.12	3.90	32.3	2.10	3.87
	80	29.6	1.87	4.26	30.5	1.87	4.26	31.5	1.88	4.26
10	60	30.1	2.24	3.55	30.6	2.24	3.49	31.2	2.24	3.43
	70	28.4	1.95	3.88	28.9	1.95	3.83	29.5	1.95	3.79
	80	26.6	1.70	4.21	27.2	1.70	4.18	27.8	1.69	4.15

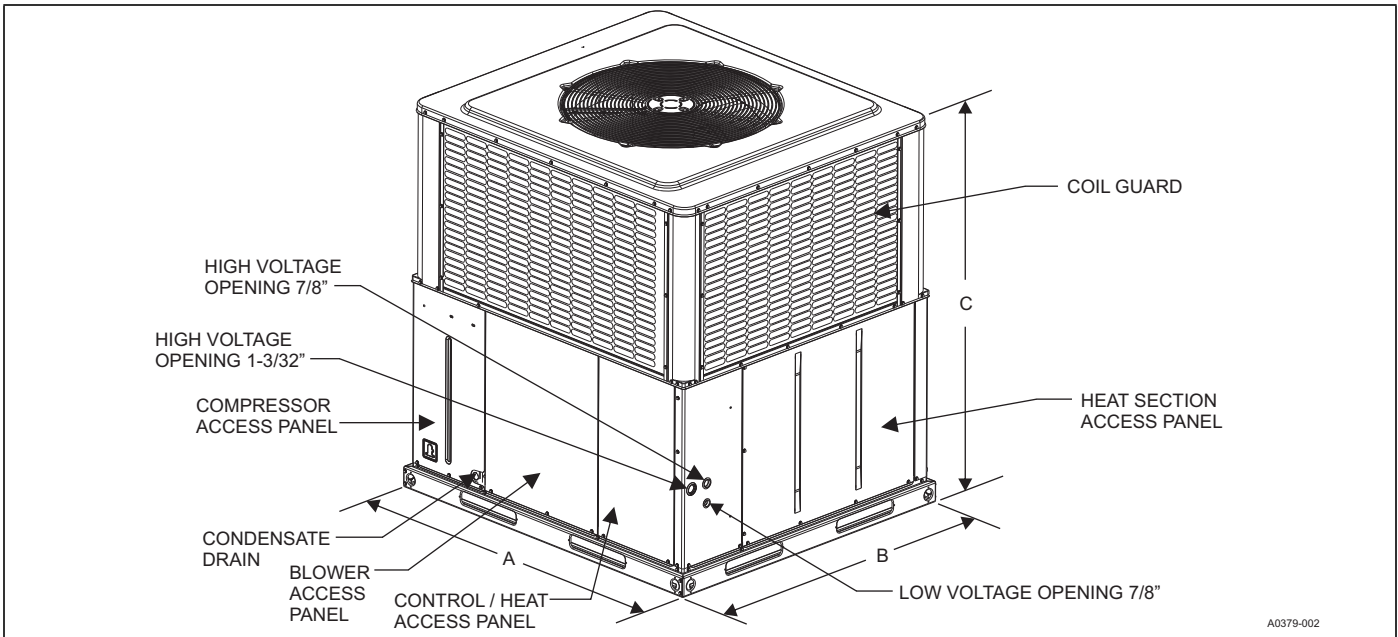

UNIT DIMENSIONS

Model	Dimensions		
	A	B	C
PHE6B3631	51-1/4	45-3/4	49
PHE6B4831	51-1/4	45-3/4	53
PHE6B6031	51-1/4	45-3/4	55

UNIT CLEARANCES

Direction	Distance (in.)	Direction	Distance (in.)
Top ¹	36	Right Side	36
Side Opposite Ducts	36	Left Side	24
Duct Panel	0	Bottom ^{2 3}	1

NOTES:

1. Minimum Clearance of 1inch all sides of supply air duct for the first 3 foot of duct for 20 & 25 kW., zero inches there after. For all other heaters, zero inch clearance all sides for entire length of duct.
 2. Units must be installed outdoors. Over hanging structure or shrubs should not obscure outdoor air discharge outlet.
 3. Units may be installed on combustible floors made from wood or class A, B or C roof covering materials.
- Note:** For units applied with a roof curb, the minimum clearance may be reduced from 1 inch to 1/2 inch? between combustible roof curb material and this supply air duct.

INDOOR BLOWER SPECIFICATIONS

Model	Motor				
	HP	RPM	EFF.	SF	Frame
PHE6B3631	1/2	Variable	0.8	1.0	48
PHE6B4831	3/4	Variable	0.8	1.0	48
PHE6B6031	1	Variable	0.8	1.0	48

COOLING SOUND PERFORMANCE

Model (Tons)	Sound Rating ¹ dB (A)	Octave Band Centerline Frequency (Hz)						
		125	250	500	1000	2000	4000	8000
PHE6B3631	73.2	61.8	63.2	60.5	64.4	58.9	53.4	45.9
PHE6B4831	74.0	62.0	62.0	60.9	64.7	60.1	56.6	49.2
PHE6B6031	74.1	65.9	61.8	60.8	63.5	58.7	55.5	48.3

1. Rated in accordance with AHRI Standard 270.

HEATING SOUND PERFORMANCE

Model (Tons)	Sound Rating ¹ dB (A)	Octave Band Centerline Frequency (Hz)						
		125	250	500	1000	2000	4000	8000
PHE6B3631	72.8	60.1	62.5	60.4	64.5	58.8	53.0	46.0
PHE6B4831	74.6	66.0	63.3	61.1	64.6	60.2	56.4	48.9
PHE6B6031	73.7	61.6	59.4	60.5	63.6	58.7	55.1	51.4

1. Rated in accordance with AHRI Standard 270.

RECOMMENDED BLOWER SPEED FOR ELECTRIC HEAT

Model	Heater kW				
	10	15	18	20	25
PHE6B36	C (ML)	A (HI)	--	--	--
PHE6B48	D (LO)	C (ML)	B (MH)	A (HI)	--
PHE6B60	D (LO)	D (LO)	C (ML)	B (MH)	A (HI)

NOTE: The recommended HEAT speed selections above will give approximately a 45 degree temperature rise at 0.3" static with 230V power supply. If lower or higher heating airflow is desired, or if duct static or voltage are different than specified, other speed taps may be used.

ELECTRICAL DATA - 208-3-60 SINGLE SOURCE POWER

Model	Compressor			OD Fan Motor	Blower Motor	Electric Heat Option				MCA ¹ (Amps)	Max Fuse ² or Breaker Size ³	MCA ¹ (Unit Less Heater)	Max Fuse ² or Breaker Size ³ (Unit Less Heater)	MCA ¹ Unit (Heater Only)	Max Fuse ² or Breaker Size ³ (Heater Only)
						Heater Kit ⁴	Heater kW	Stages	Heater Amps						
	RLA	LRA	MCC	FLA	FLA		208		208	208	208	208	208	208	208
PHE6B36	11.6	73.0	18.1	1.7	3.8	none	--	--	--	20.0	30	20.0	30	-	-
						6HK06501025	7.2	1	20.0	45.0	50	20.0	30	25.0	25
						6HK06501525	10.8	1	30.0	57.5	60	20.0	30	37.5	40
PHE6B48	14.0	83.1	21.9	1.7	5.4	none	--	--	--	24.6	35	24.6	35	-	-
						6HK06501025	7.2	1	20.0	49.6	50	24.6	35	25.0	25
						6HK06501525	10.8	1	30.0	62.1	70	24.6	35	37.5	40
						6HK06501825	13.0	1	36.1	69.7	70	24.6	35	45.1	50
						6HK16502025	14.4	2	40.0	74.6	80	24.6	35	50.0	*
PHE6B60	16.2	110.0	25.3	1.7	7.0	none	--	--	--	29.0	45	29.0	45	-	-
						6HK06501025	7.2	1	20.0	53.9	60	29.0	45	25.0	25
						6HK06501525	10.8	1	30.0	66.4	70	29.0	45	37.5	40
						6HK06501825	13.0	1	36.1	74.1	80	29.0	45	45.1	50
						6HK16502025	14.4	2	40.0	78.9	80	29.0	45	50.0	*
						6HK16502525	18.0	2	50.0	91.4	100	29.0	45	62.5	*

NOTES: Single-source power MCA and MOP requirements are given here for reference if the unit is to be installed with a field-installed single-point power modification.

* - Breakers for heaters are included in the 20kW and 25kW heater kits.

1. Minimum Circuit Ampacity.

2. Maximum Over Current Protection per standard UL 1995.

3. Fuse or HACR circuit breaker to be field installed.

4. Single Point Connection Kit required.

ELECTRICAL DATA - 208-3-60 MULTI SOURCE POWER

Model	Compressor			OD Fan Motor	Blower Motor	Electric Heat Option				MULTI SOURCE					
						Heater Kit	Heater kW	Stages	Heater Amps	208		208		208	
	RLA	LRA	MCC	FLA	FLA		208		208	208	208	208	208	208	208
MULTI SOURCE: COMPRESSOR CIRCUIT AND HEAT CIRCUITS						MULTI SOURCE: CIRCUIT #1 COMPRESSOR CIRCUIT #2 1ST STAGE HEAT CIRCUIT #3 2ND STAGE HEAT				MCA ¹ Amps	Max Fuse ² or Breaker Size ³	MCA ¹ Amps	Max Fuse ² or Breaker Size ³	MCA ¹ Amps	Max Fuse ² or Breaker Size ³
										CIRCUIT #1		CIRCUIT #2		CIRCUIT #3	
PHE6B36	11.6	73.0	18.1	1.7	3.8	none	--	--	--	20.0	30	--	--	--	--
						6HK06501025	7.2	1	20.0	20.0	30	25.0	25	--	--
						6HK06501525	10.8	1	30.0	20.0	30	37.5	40	--	--
PHE6B48	14.0	83.1	21.9	1.7	5.4	none	--	--	--	24.6	35	--	--	--	--
						6HK06501025	7.2	1	20.0	24.6	35	25.0	25	--	--
						6HK06501525	10.8	1	30.0	24.6	35	37.5	40	--	--
						6HK06501825	13.0	1	36.1	24.6	35	45.1	50	--	--
						6HK16502025	14.4	2	40.0	24.6	35	25.0	25	25.0	25
PHE4B60	16.2	110.0	25.3	1.7	7.0	none	--	--	--	29.0	45	--	--	--	--
						6HK06501025	7.2	1	20.0	29.0	45	25.0	25	--	--
						6HK06501525	10.8	1	30.0	29.0	45	37.5	40	--	--
						6HK06501825	13.0	1	36.1	29.0	45	45.1	50	--	--
						6HK16502025	14.4	2	40.0	20.0	45	25.0	25	25.0	25
						6HK16502525	18.0	2	50.0	29.0	45	31.3	35	31.3	35

NOTE:

1. Minimum Circuit Ampacity.

2. Maximum Over Current Protection per standard UL 1995.

3. Fuse or HACR circuit breaker to be field installed.

ELECTRICAL DATA FOR - 230-3-60 SINGLE SOURCE POWER

Model	Compressor			OD Fan Motor	Blower Motor	Electric Heat Option				MCA ¹ (Total Unit)	Max Fuse ² or Breaker Size ³ (Total Unit)	MCA ¹ (Unit Less Heater)	Max Fuse ² or Breaker Size ³ (Unit Less Heater)	MCA ¹ Unit (Heater Only)	Max Fuse ² or Breaker Size ³ (Heater Only)
						Heater Kit ⁴	Heater kW	Stages	Heater Amps						
	RLA	LRA	MCC	FLA	FLA					230	230	230	230	230	230
PHE6B36	11.6	73.0	18.1	1.7	3.8	none	--	--	--	20.0	30	20.0	30	-	-
						6HK06501025	8.8	1	22.1	47.6	50	20.0	30	27.6	30
						6HK06501525	13.2	1	33.1	61.4	70	20.0	30	41.4	45
PHE6B48	14.0	83.1	21.9	1.7	5.4	none	--	--	--	24.6	35	24.6	35	-	-
						6HK06501025	8.8	1	22.1	52.2	60	24.6	35	27.6	30
						6HK06501525	13.2	1	33.1	66.0	70	24.6	35	41.4	45
						6HK06501825	15.9	1	39.9	74.5	80	24.6	35	49.9	50
						6HK16502025	17.6	2	44.2	79.8	80	24.6	35	55.2	*
PHE6B60	16.2	110.0	25.3	1.7	7.0	none	--	--	--	29.0	45	29.0	45	-	-
						6HK06501025	8.8	1	22.1	56.6	60	29.0	45	27.6	30
						6HK06501525	13.2	1	33.1	70.4	80	29.0	45	41.4	45
						6HK06501825	15.9	1	39.9	78.8	80	29.0	45	49.9	50
						6HK16502025	17.6	2	44.2	84.2	90	29.0	45	55.2	*
						6HK16502525	22.0	2	55.2	98.0	100	29.0	45	69.0	*

NOTES: Single-source power MCA and MOP requirements are given here for reference if the unit is to be installed with a field-installed single-point power modification.

* - Breakers for heaters are included in the 20kW and 25kW heater kits.

1. Minimum Circuit Ampacity.

2. Maximum Over Current Protection per standard UL 1995.

3. Fuse or HACR circuit breaker to be field installed.

4. Single Point Connection Kit required.

ELECTRICAL DATA FOR 230-3-60 MULTI SOURCE POWER

Model	Compressor			OD Fan Motor	Blower Motor	Electric Heat Option				MULTI SOURCE					
						Heater Kit	Heater kW	Stages	Heater Amps	230	230	230	230	230	230
	RLA	LRA	MCC	FLA	FLA										
MULTI SOURCE: COMPRESSOR CIRCUIT AND HEAT CIRCUITS						MULTI SOURCE: CIRCUIT #1 COMPRESSOR CIRCUIT #2 1ST STAGE HEAT CIRCUIT #3 2ND STAGE HEAT				MCA¹ Amps	Max Fuse² or Breaker Size³	MCA¹ Amps	Max Fuse² or Breaker Size³	MCA¹ Amps	Max Fuse² or Breaker Size³
										CIRCUIT #1		CIRCUIT #2		CIRCUIT #3	
PHE6B36	11.6	73.0	18.1	1.7	3.8	none	--	--	--	20.0	30	--	--	--	--
						6HK06501025	8.8	1	22.1	20.0	30	27.6	30	--	--
						6HK06501525	13.2	1	33.1	20.0	30	41.4	45	--	--
PHE6B48	14.0	83.1	21.9	1.7	5.4	none	--	--	--	24.6	35	--	--	--	--
						6HK06501025	8.8	1	22.1	24.6	35	27.6	30	--	--
						6HK06501525	13.2	1	33.1	24.6	35	41.4	45	--	--
						6HK06501825	15.9	1	39.9	24.6	35	49.9	50	--	--
						6HK16502025	17.6	2	44.2	24.6	35	27.6	30	27.6	30
PHE4B60	16.2	110.0	25.3	1.7	7.0	none	--	--	--	29.0	45	--	--	--	--
						6HK06501025	8.8	1	22.1	29.0	45	27.6	30	--	--
						6HK06501525	13.2	1	33.1	29.0	45	41.4	45	--	--
						6HK06501825	15.9	1	39.9	29.0	45	49.9	50	--	--
						6HK16502025	17.6	2	44.2	29.0	45	27.6	30	27.6	30
						6HK16502525	22.0	2	55.2	29.0	45	34.5	35	34.5	35

NOTE:

1. Minimum Circuit Ampacity.

2. Maximum Over Current Protection per standard UL 1995.

3. Fuse or HACR circuit breaker to be field installed.

SINGLE-POINT WIRING KIT PART NUMBERS

Unit Model Number	Voltage	Heater Kit	Single-Point Wiring Kit	Unit Fuse Size (A)	Heater Fuse Size (A)
PHE6B3631	208-3-60	6HK06501025	S1-2SPWK031	30	25
		6HK06501525	S1-2SPWK033	30	40
PHE6B4831	208-3-60	6HK06501025	S1-2SPWK032	35	25
		6HK06501525	S1-2SPWK034	35	40
		6HK06501825	S1-2SPWK034	35	50
		6HK16502025	S1-2SPWK035	35	N/A*
PHE6B6031	208-3-60	6HK06501025	S1-2SPWK032	45	25
		6HK06501525	S1-2SPWK034	45	40
		6HK06501825	S1-2SPWK034	45	50
		6HK16502025	S1-2SPWK035	45	N/A*
		6HK16502525	S1-2SPWK035	45	N/A*
Unit Model Number	Voltage	Heater Kit	Single-Point Wiring Kit	Unit Fuse Size (A)	Heater Fuse Size (A)
PHE6B3631	230-3-60	6HK06501025	S1-2SPWK031	30	30
		6HK06501525	S1-2SPWK033	30	45
PHE6B4831	230-3-60	6HK06501025	S1-2SPWK032	35	30
		6HK06501525	S1-2SPWK034	35	45
		6HK06501825	S1-2SPWK034	35	50
		6HK16502025	S1-2SPWK035	35	N/A*
PHE6B6031	230-3-60	6HK06501025	S1-2SPWK032	45	30
		6HK06501525	S1-2SPWK034	45	45
		6HK06501825	S1-2SPWK034	45	50
		6HK16502025	S1-2SPWK035	45	N/A*
		6HK16502525	S1-2SPWK035	45	N/A*

NOTES:

* - the 208/230 volt 20kW and 25kW heater kits include circuit breakers, so no fuse is needed

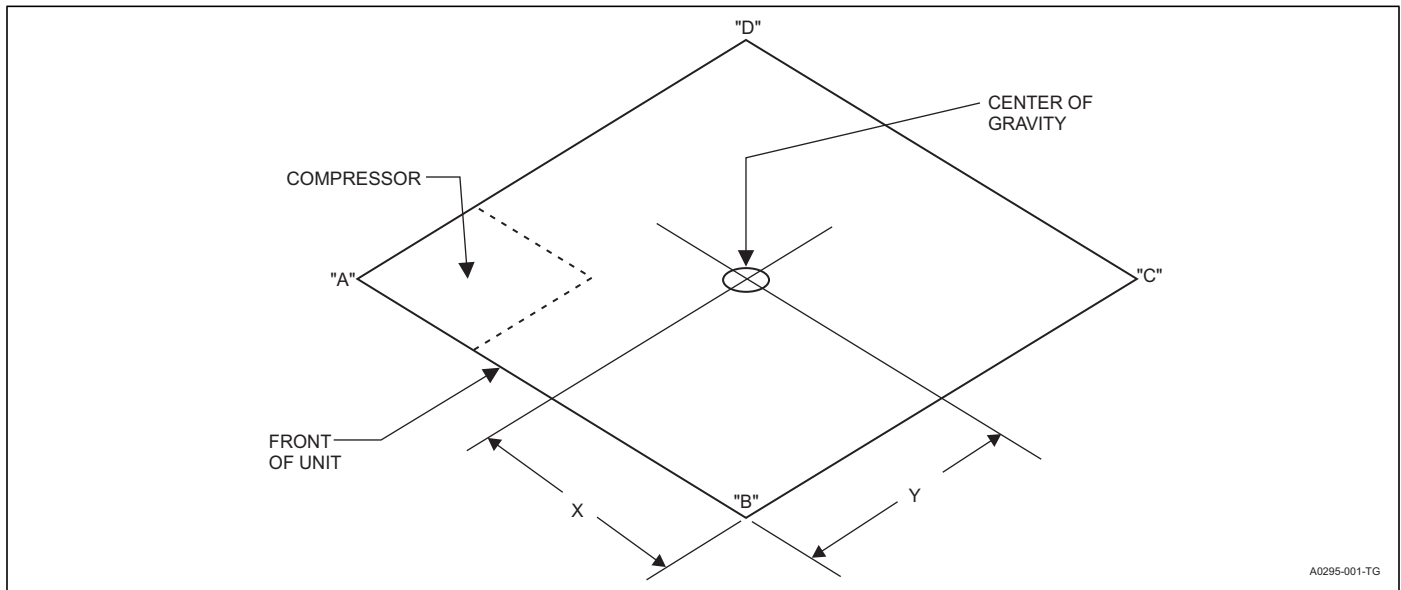

WEIGHTS & DIMENSIONS

Model	Weight (lbs.)		Center of Gravity		4 Point Load Location (lbs.)			
	Shipping	Operating	X	Y	A	B	C	D
PHE6B3631	453	448	29	15	158	108	101	86
PHE6B4831	501	496	29	15	168	130	119	84
PHE6B6031	528	523	30	15	177	136	128	87

AIRFLOW PERFORMANCE - SIDE DUCT APPLICATION

Model	Jumper Position		External Static Pressure (Inches WC)									
			0.1	0.2	0.3	0.4	0.5	0.6	0.7	0.8	0.9	1.0
			SCFM	SCFM	SCFM	SCFM	SCFM	SCFM	SCFM	SCFM	SCFM	SCFM
PHE6A36	High Cool/Heat	A	1345	1318	1271	1222	1172	1108	1035	961	894	841
		B	1264	1211	1170	1115	1056	981	894	826	775	729
		C	1232	1178	1131	1077	1012	929	853	790	738	690
		D	1058	999	931	859	762	694	635	582	523	459
	Low Cool/Heat	A	1153	1095	1036	979	899	810	751	697	643	588
		B	1015	952	884	802	709	646	582	528	467	402
		C	882	805	741	625	556	501	415	359	297	228
		D	805	718	642	523	436	376	294	247	193	118
	Electric Heat	A	1190	1133	1079	1026	953	861	798	742	689	638
		B	1112	1054	991	928	840	760	701	648	591	532
		C	955	886	821	721	642	584	508	453	391	324
		D	856	776	708	591	516	459	375	321	262	191
PHE6A48	High Cool/Heat	A	1851	1809	1781	1746	1707	1656	1609	1552	1518	1460
		B	1689	1652	1630	1597	1556	1504	1461	1404	1368	1310
		C	1614	1578	1554	1520	1477	1424	1382	1324	1286	1228
		D	1374	1333	1298	1255	1204	1145	1100	1044	993	933
	Low Cool/Heat	A	1473	1435	1406	1368	1320	1264	1220	1164	1119	1060
		B	1374	1333	1298	1255	1204	1145	1100	1044	993	933
		C	1322	1278	1238	1191	1138	1077	1030	975	920	859
		D	1286	1241	1197	1149	1095	1032	984	930	872	810
	Electric Heat	A	1441	1407	1373	1325	1279	1232	1182	1108	1042	1039
		B	1327	1286	1242	1192	1143	1081	1024	949	881	834
		C	1187	1136	1084	1028	968	886	827	767	702	657
		D	1087	1031	974	909	832	750	704	653	600	537
PHE6A60	High Cool/Heat	A	2149	2114	2077	2030	1989	1948	1905	1859	1816	1768
		B	2013	1977	1941	1898	1860	1816	1772	1726	1677	1630
		C	1936	1900	1864	1822	1783	1739	1695	1649	1597	1551
		D	1719	1685	1642	1600	1555	1508	1465	1418	1372	1327
	Low Cool/Heat	A	1629	1591	1546	1502	1455	1409	1362	1315	1266	1220
		B	1558	1516	1469	1423	1375	1329	1280	1232	1181	1135
		C	1453	1406	1355	1305	1255	1207	1153	1100	1047	997
		D	1410	1361	1307	1255	1204	1155	1100	1044	992	938
	Electric Heat	A	1743	1712	1666	1623	1580	1540	1493	1449	1404	1370
		B	1485	1436	1380	1329	1283	1234	1185	1139	1084	1032
		C	1382	1324	1265	1210	1162	1108	1059	1012	952	891
		D	1205	1131	1066	1005	953	892	841	793	724	644

NOTES:

1. Airflow tested with dry coil conditions, without air filters, at 230 volts.
2. Applications above 0.8" w.c. external static pressure are not recommended.
3. Brushless DC high efficiency standard ECM blower motor used for all indoor blower assemblies.
4. Minimal variations in airflow performance data results from operating at 208 volts. Data above may be used in those cases.
5. Minimal variations in airflow performance data results from using downflow duct applications. Data above may be used in those cases.
6. Heating applications tested at 0.50" w.c. esp, and cooling applications tested at 0.30" w.c. esp per standards.

ADDITIONAL STATIC RESISTANCE

Size (Tons)	CFM	Wet Indoor Coil	Economizer ¹	Filter/Frame Kit
36 (3.0)	700	0.01	0.00	0.04
	800	0.02	0.01	0.06
	900	0.03	0.01	0.08
	1000	0.04	0.01	0.10
	1100	0.05	0.01	0.13
	1200	0.06	0.02	0.16
	1300	0.07	0.03	0.17
	1400	0.08	0.04	0.18
48 (4.0)	1100	0.02	0.02	0.04
	1200	0.03	0.02	0.04
	1300	0.04	0.02	0.05
	1400	0.05	0.03	0.05
	1500	0.06	0.04	0.06
	1600	0.07	0.04	0.07
	1700	0.07	0.04	0.08
	1800	0.08	0.04	0.09
	1900	0.09	0.05	0.10
	2000	0.09	0.05	0.11
60 (5.0)	1100	0.02	0.02	0.04
	1200	0.03	0.02	0.04
	1300	0.04	0.02	0.05
	1400	0.05	0.03	0.05
	1500	0.06	0.04	0.06
	1600	0.07	0.04	0.07
	1700	0.07	0.04	0.08
	1800	0.08	0.04	0.09
	1900	0.09	0.05	0.10
	2000	0.09	0.05	0.11

1. The pressure drop through the economizer is greater for 100% outdoor air than for 100% return air. If the resistance of the return air duct is less than 0.25 IWG, the unit will deliver less CFM during full economizer operation. Filter pressure drop based on standard filter media tested at velocities not to exceed 300 ft/min.

BOTTOM DUCT DIMENSIONS (Inches)

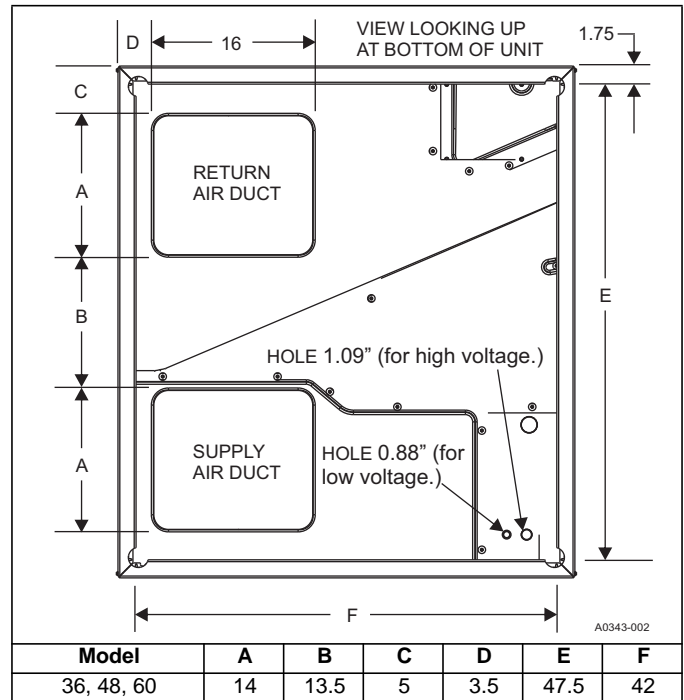

REAR DUCT DIMENSIONS (Inches)

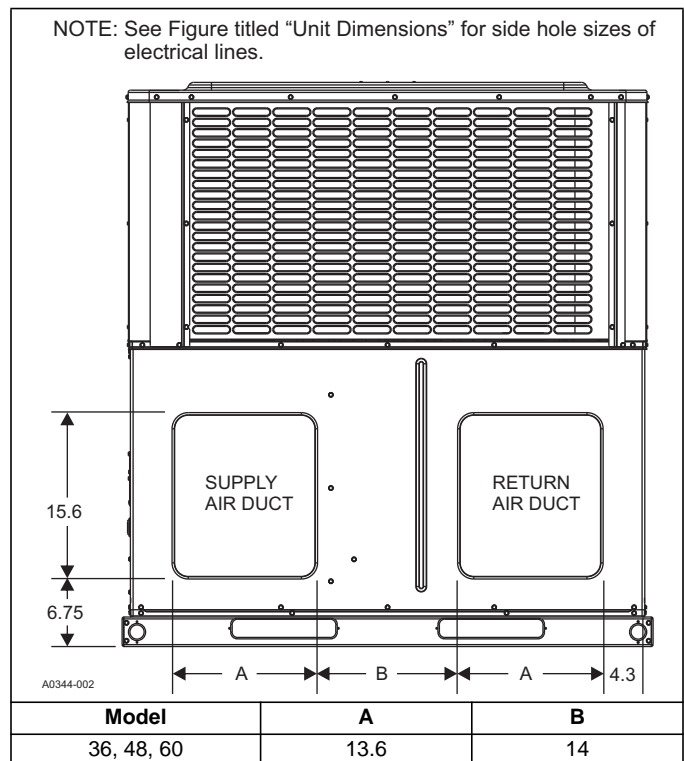

UNIT TYPICAL DUCT APPLICATIONS

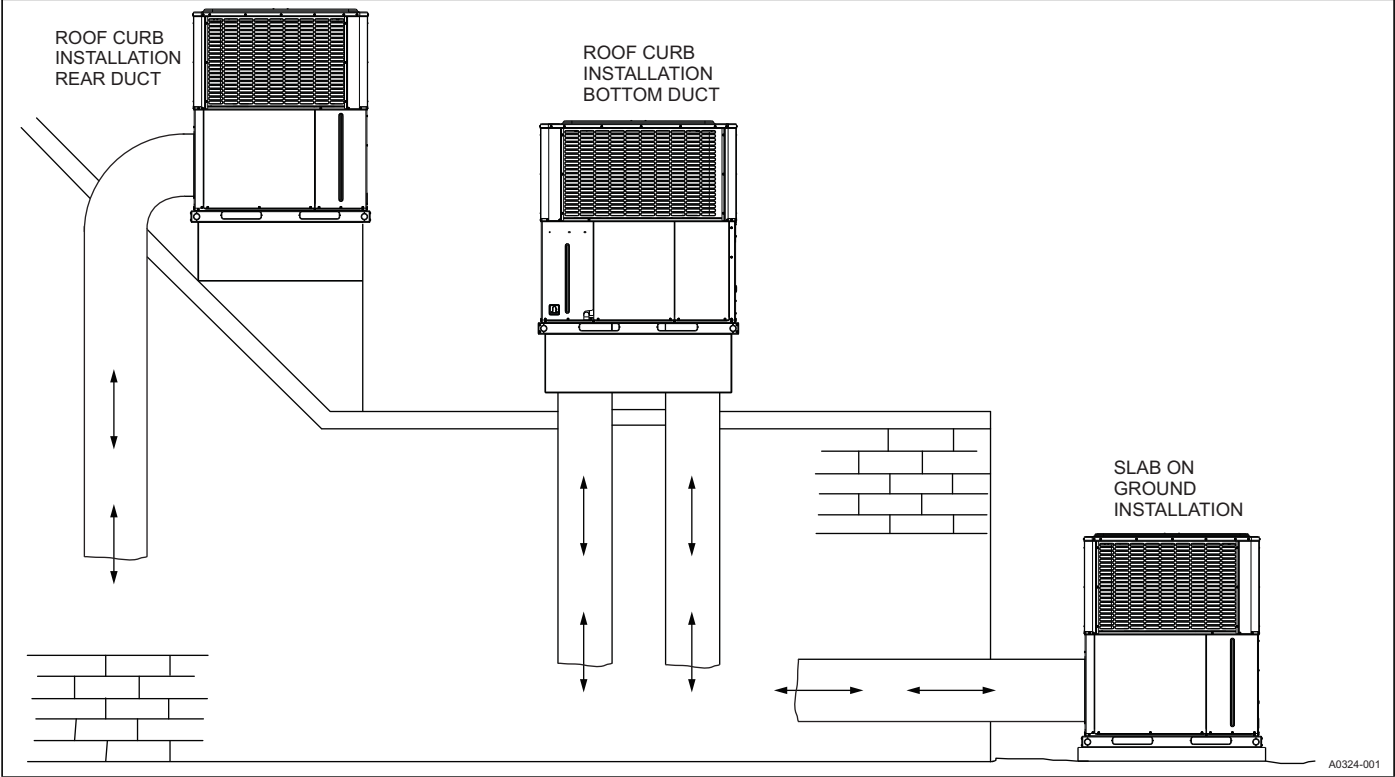

UNIT TYPICAL SLAB ON GROUND INSTALLATION

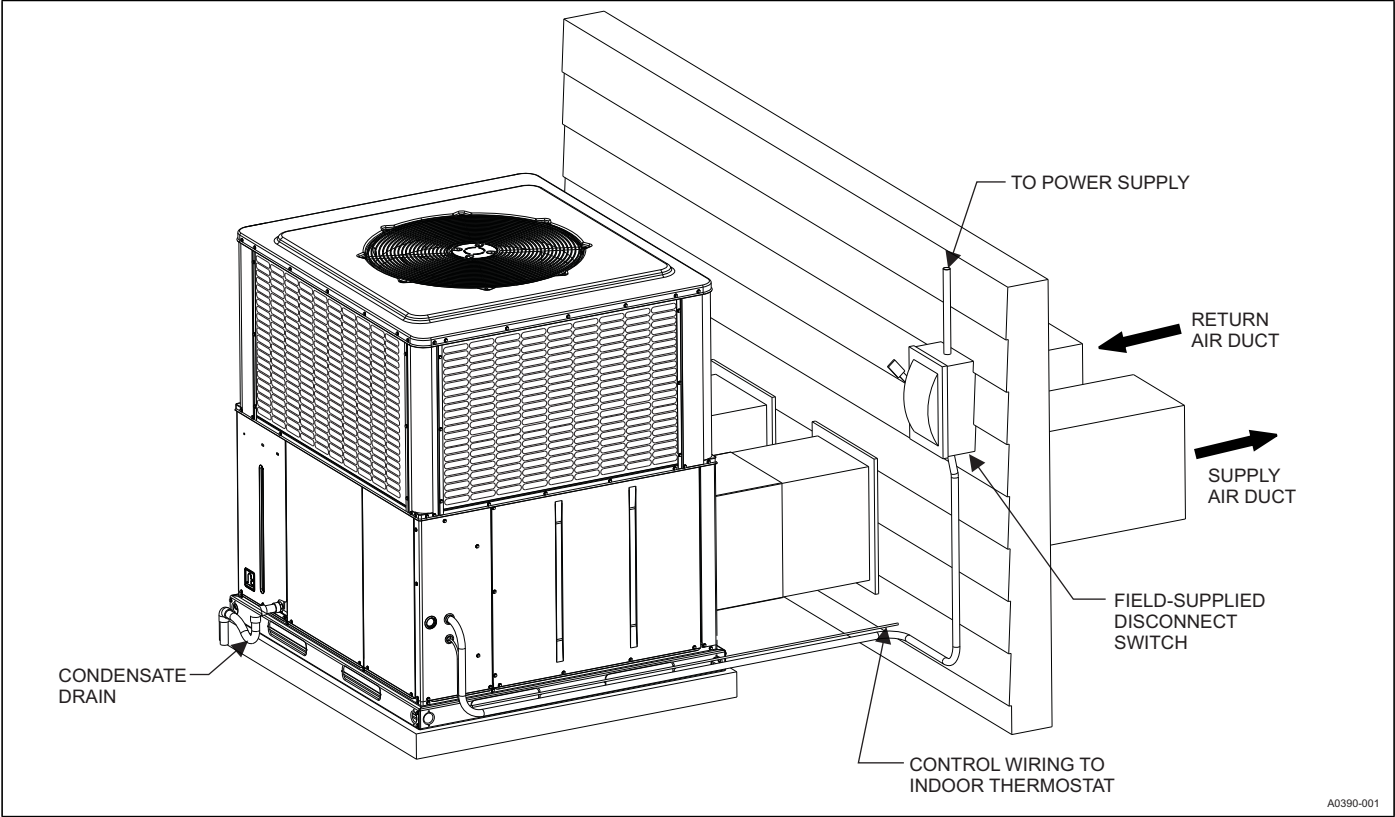

UNIT TYPICAL ROOF CURB INSTALLATION

